

R environments

Johan Zetterqvist

May 12, 2016

Why bother?

- ▶ Sometimes things don't work as expected.
- ▶ When writing functions it is important to know how R looks for variables.
- ▶ When writing packages it is important to know how R looks for functions.

What is an environment?

- ▶ A 'frame', i.e. the name-object bindings

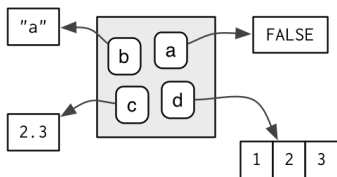

- ▶ A parent, i.e. a pointer to another environment

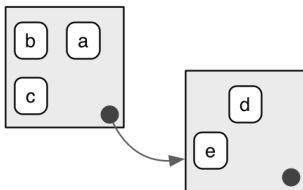

- ▶ Exception: the empty environment - the grandfather of all environments.

The environment tree

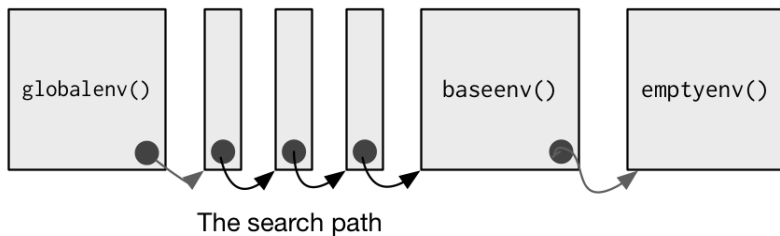

Searching for variables

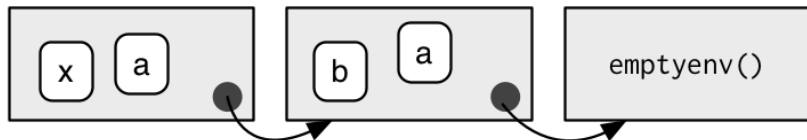

- ▶ Which 'a' is used ?
- ▶ How to find 'b' ?
- ▶ How to find 'x' ?

Functions and their environments

A function has 4 associated environments:

- ▶ The enclosing environment - where the function was created
- ▶ The binding environment - where the function have a name
- ▶ The execution environment - the temporary environment used during execution containing local variables
- ▶ The calling environment - the environment where the function was called

The enclosing environment

- ▶ This is where the function was created

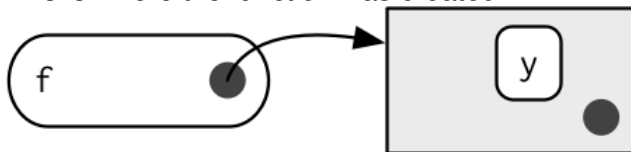

`globalenv()`

Determines

how the function finds its values

The binding environment

- ▶ This is where the function have a name - determines how

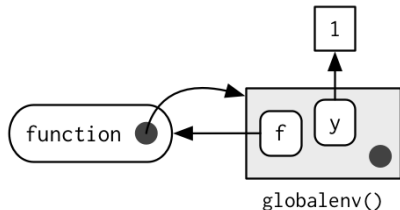

we can find the function

- ▶ Not necessarily the same as the enclosing environment

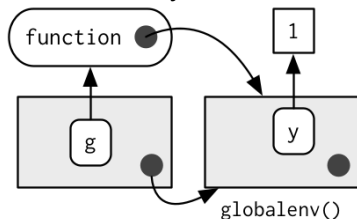

The execution environment

1. Function called with $x = 1$

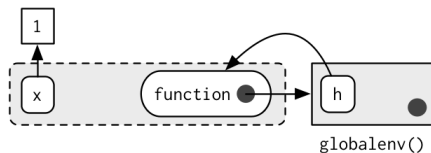

2. `a` assigned value 2

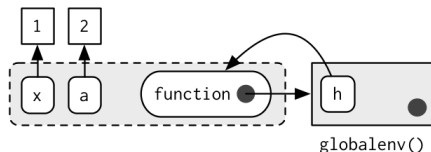

3. Function completes returning value 3.
Execution environment goes away.

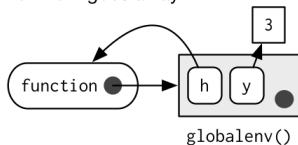

The calling environment

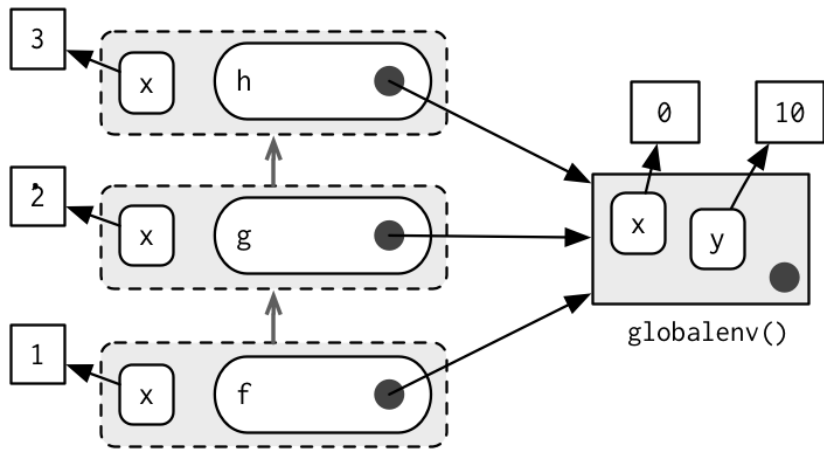

Packages and environments

There are two environments associated with a package:

- ▶ A package environment - a binding environment
- ▶ A namespace - an enclosing environment

Package environment

- ▶ exported functions bound to this environment
- ▶ where these functions are found (by name)
- ▶ inserted below the global environment in the environment stack
- ▶ have a special parent - an 'imports environment'

Namespace

- ▶ exported functions are enclosed by this environment
- ▶ the 'creation' environment for the functions
- ▶ where variables and other functions are looked for
- ▶ inserted above the global environment in the environment stack during function call

namespace vs package environment

